

OPERATING AND MAINTENANCE MANUAL
ALFA WAFER BALL VALVES
Models ALFA 10N / 10NF / 103 / 10HP

INDEX	PAGE
0. Technical Data	2
1. Transportation, handling and storage	3
2. Installation instructions	3
3. Maintenance	5
4. Testing	5
5. How to order spare parts	5
6. Warnings and use limitations	6
7. Trouble shooting	7
8. Maintenance card	8

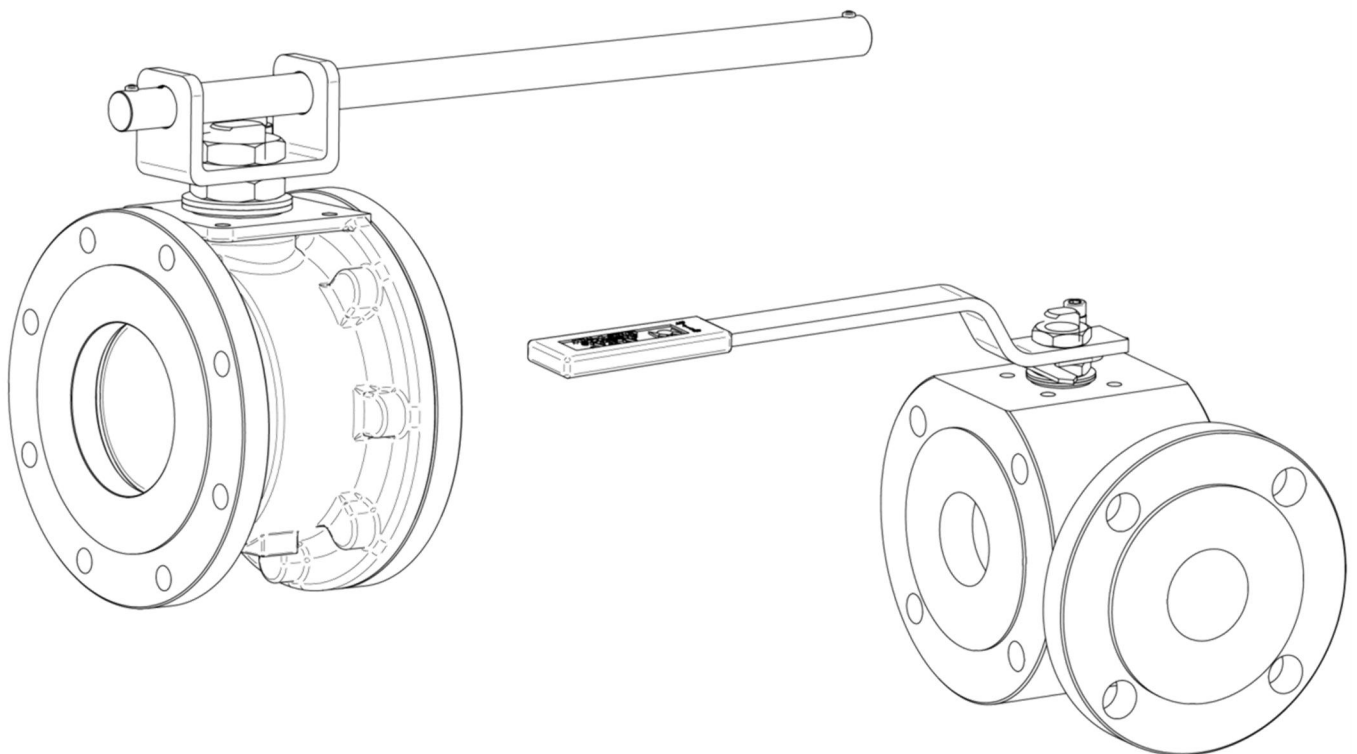

0. TECHNICAL DATA

0.1 MANUFACTURER

ALFA VALVOLE S.r.l.

V.le del Lavoro 19 - 20010 CASOREZZO (MI) – ITALY

Ph. +39-0290296206

Fax. +39-0290296292

E-mail alfavalvole@alfavalvole.it

0.2 ALLOWED USE AND LIMITS

Operators involved in the storage, mounting, use and/or maintenance of our products are requested to have sufficient skill and experience in such a kind of equipment. It is user responsibility to guarantee this skill is met.

Service: ON-OFF and deviation of liquids e gases (A103 type valves, only)

Fluids: Liquids e gases Group 1 (dangerous), not unstable, according to the European Directive 2014/68/UE “PED”, art. 13 – Category III



Use in potentially explosive atmospheres : II 2 GD c T6 X according to the EC Directive 94/9/EC “ATEX”

Minimum guaranteed tightness limits on brand new valve:

Emissions to atmosphere	on request, according to TA-LUFT and/or ISO 15848-1 requirements
Hydrostatic Body Test	(1,5 x Maximum working pressure at room temperature) Zero Leakage
Hydrostatic Seat Test	(1,1 x Maximum working pressure at room temperature) Zero Leakage
Pneumatic Seat Test	(Air, 6 bar) Zero Leakage

“Fire Safe” features: on request, according to ISO 10497 / API 607 / API 6FA / BS 6755, (A103 type valves excluded).

Model	ALFA 10N ALFA 10NF ALFA 103	ALFA 10N ALFA 10NF ALFA 103	ALFA 10N ALFA 10NF ALFA 103	ALFA 10HP ALFA 103	
Class	PN10-16 ANSI 150	PN25- 40	ANSI 300	PN63 PN100 ANSI 600	
Nominal Diameters	DN10÷200 (ALFA103 DN15÷150)	DN10÷200 (ALFA103 DN15÷150)	DN 15÷200 (ALFA103 DN15÷150)	DN10÷100 (ALFA103 DN15÷100)	
Maximum working pressure at room temperature (bar)	10 PN10	25 PN25	51	63 PN63	
	16 PN16	40 PN40		102 PN100	
	20 A.150			63 DN>80	
Maximum working pressure at maximum temperature (bar)	8	8	15	102 A.600	
				63 DN>80	
				63 DN>80	
Pressure values between room temperature and maximum temperature vary depending of characteristics of used seats/seals materials. Please contact ALFA VALVOLE Technical Dept. for more information.					
Maximum working Temperature **	200°C	DN 10 - 50 (Ø ¾" – 2")		90°C	DN 10 - 50 (Ø ¾" – 2")
	180°C	DN 65 – 80 (Ø 2½" – 3")			
	160°C	DN 100 – 150 (Ø 4" – 6")		70°C	DN 65 - 100 (Ø 2½" – 4")
	120°C	DN 200 (Ø 8")			
Minimum working and room temperature	-29°C**	for carbon steel A105 / A216 WCB valve bodies	with impact test verification when TR* ≤ 21°C		
	-40°C**	for carbon steel A350 LF2 / A352 LCB valve bodies	With impact test verification (valve without O-Ring and with Chevron Ring)		
	-46°C**	for carbon steel A350 LF2 / A352 LCB valve bodies	without impact test verification		
	-40°C**	for stainless steel valve bodies	Without impact test verification (valve without O-Ring and with Chevron Ring)		
-70°C**	for stainless steel valve bodies	Without impact test verification (valve without O-Ring and with Chevron Ring)			
Maximum simultaneous working conditions	Please contact ALFA VALVOLE Technical Dept.				

* TR = design temperature, for impact test verification, according to the standard EN13445-2 “Unfired Pressure Vessels – Materials”, para 4.1.6 e Annex B. The body thickness is assigned so that the design temperature, for impact test verification according to the standard EN13445-2, are above 21 ° C.

** Other restrictions imposed from the material of the seat ring, the gasket material and the nominal diameter of the valve will be indicated on the nameplate attached to the valve body.

Table of nominal dimensions of valves

DN	10	15	20	25	32	40	50	65	80	100	125	150	200
Ø"	¾"	½"	¾"	1"	1 ¼"	1 ½"	2"	2 ½"	3"	4"	5"	6"	8"

0.3 SPECIFIC DESIGN PROCEDURES

END CONNECTIONS	Flanged ANSI/DIN/UNI/EN with blind or straight screwed holes
BODY THICKNESS	ASME VIII Div.1 – ASME B16.34 – DIN 3840
BOLTING DESIGN	ASME VIII Div.1 – ASME B16.34 (Split Body only)
SCREWED CONNECTION DESIGN	ASME B16.34 (Screwed Connector only)
FLANGE DESIGN	ASME VIII Div.1 (Split Body only)
SIMULTANEOUS LOADS	Pressure, Bending, Axial Loads from piping
WIND LOADS	Negligible, according to ASME III Div.1 Subsect.NB
EARTHQUAKE LOADS	Negligible, according to ASME III Div.1 Subsect.NB
FATIGUE from On-Off starting cycles	Negligible, according to ASME III Div.1 Subsect.NB (see the maximum number of operating hours)
FATIGUE from service pressure fluctuation	Negligible, according to ASME III Div.1 Subsect.NB (see the maximum number of operating hours)
MAXIMUM LIFE IN SERVICE HOURS	Function of actual simultaneous working conditions and fluids but anyway not longer than : 100.000 hours (see para 3.1 for recommended periodical inspections);
	OR (depending on the conditions that happen first)
	50.000 operations of opening/closing of the valve (liquid service)
	5.000 operations of opening/closing of the valve (gas service)
	1.500 pressurization-depressurization cycles (Carbon Steel valves)
	13.000 pressurization-depressurization cycles (Stainless Steel Valves)
AVAILABLE CORROSION OVERTHICKNESS	1.5 mm min. (carbon steel valves only)
ANTISTATIC FEATURES	according to API 6D app. B5

1. TRANSPORT, HANDLING AND STORAGE

1.1 TRANSPORT AND HANDLING

Valves must be transported and handled maintaining the ball in the open position.
 DO NOT remove the protection caps from the ends until the valve is to be mounted in line.

Avoid impacts against obstacles that may damage the stem or the auxiliary connections (drains, sealant injectors, vents).

1.2 STORAGE

Valves with carbon steel or stainless steel bodies must both be stored with ball in the OPEN position and in a location dry and free from fumes, gas or corrosive vapours.

For long storage periods it is advisable to cover the external surface with a layer of protective wax (Tectyl) or close the valves in polythene bags.

2. INSTALLATION INSTRUCTIONS

The installation procedure for ball valves is critical to ensuring both long life and satisfying performance. Valves stored on site awaiting installation should be kept in their original packing, in dry conditions, where damage cannot occur.

Before carrying out the installation, it is important to follow the basic procedures described below:

2.1 General

- Carefully unpack the valve and check valve nameplate for identification of materials.
- Remove all packing materials.
- All valves are bi-directional and supplied ready to use. Valves can be placed with stem oriented to any direction.

- Check the valve for any flow direction indication marks. Appropriate care must be taken, to install the valve for proper flow orientation.
- Inspect the valve interior through the end ports to determine it is clean and free from foreign matter according to ASME G93-03E1.
- Ensure that all auxiliary connections, if any, (lubricators, drains, vents) are free of damage and properly tightened.
- Cycle the valve and inspect any functionally significant features.
- Read all the literature and note any special warning tags or plates attached to the valve.
- Before installation check to insure the ball is in the fully open position in order to prevent possible damage to the ball and seats. The valve performance depends on its original conditions. At any stage do not leave the valve in the partially open position.

2.2 Threaded End Valves

- Valves with threaded ends should be treated as a single unit and should not be dismantled when installing to pipeline.
- Before installing the valves, make sure that the threads on the mating pipe are free from excessive grit, dirt or burrs.
- When tightening the valve, apply a pipe wrench or spanner to the end connector closest to the pipe being worked, using standard piping practices.
- Use appropriate joining sealants material in correct quantities.

2.3 Weld End Valves in-line

- Welding of valves shall be performed by a qualified person according to the ASME Boiler Construction Code Section IX. For valves to be welded within the E.U., refer to the requirements of ESR 3.1.2 of the Pressure Equipment Directive 97/23/EC.
- Valves that will be welded directly to the line must be in the fully open position to protect the ball and seats from excessive temperatures during the welding procedures.
- Protect or remove actuators from weld splatter or arc strikes. Valves in the "Fail Close" position should be cycled to the open position.
- Allow free flow of water through the drain bottom valve and overflow through the vent valve to prevent overheating all through the welding process. **DO NOT** heat the center section over 150°C
- Align valve to pipe line, ensuring proper fit to minimize pipe load. Tack weld only.
- Complete welding in small segments. Allow enough time for cooling between each segment.
- Do not rotate the valve before flushing the line.

2.4 Flanged End Valves

- Valves with flanged ends should be treated as a single unit and should not be dismantled when installing to pipeline.
- Before installing the valves, make sure that the flanges on the mating pipe are free from excessive grit, dirt or burrs, and that there is no mechanical damage to the flanges on the pipe.
- When inserting the flange bolts, make sure the bolts are correct size to hold pressure and axial forces.



ATTENTION: When the valve installation has been completed, a full functional test needs to be performed.

The test must verify the valve's ability to open and close completely, whether it is activated manually or with the help of gearboxes or actuators and, if applicable, the correct operation of position indicators and/or other auxiliary devices.

The acceptance criteria will be as follows:

- It must be possible to move the ball between open and closed positions.
- Any position indicator and/or auxiliary devices must indicate the correct position of the ball

For more detailed information about the test performing, refer to the document "IOC 001 – OPERATING INSTRUCTION FOR FINAL TESTING OF BALL VALVES", para.9 – Functional Testing.

ALFA VALVOLE Ball Valves provide tight shut off when used under normal conditions and in accordance with ALFA VALVOLE published pressure/temperature chart.

Valve operation works by operating the valve handle 90° turn counter-clockwise to open, and 90° turn clockwise to close. All standard valves are bidirectional and as such, can be installed for flow in either direction.

Valves which are unidirectional will have a flow direction arrow welded to the body and separate assembly instructions.

A lubricant is applied through grease fittings on both ends and gland, to assist valve break in. The lubricant, if unacceptable, may be removed by a solvent wash.

If a shut-off valve is installed for end of line service, it must be ensured that it is closed with a blind end connection and the valve is secured against being opened unintentionally.

WARNING: Never look into the valve bore while the valve is in a flow-line. Pressure and fluids could escape from the valve causing injury. To prevent leakage, malfunctions resulting from internal wear or seal degradation, the user must establish a preventive maintenance and inspection program. This program must include:

- a. Inspection of parts to detect loss of wall thickness which may result in decreased pressure capacity
- b. Routine replacement of seals and inspection for proper operation.

3. MAINTENANCE

3.1 A general control of the valve is advisable every 2 years of functioning or every 5.000 opening and closing cycles.

3.1.1 Remove electric and pneumatic or hydraulic actuators power supplies before removing the valve from piping or before any maintenance or cleaning adjustment.

ATTENTION: check absence of electric and pneumatic or hydraulic actuators power supplies before disconnecting. The execution of eventual intervention must follow the procedure illustrated on the attached card.

In occurrence of dirty fluids interception, more frequent periodic checks are recommended, please contact ALFA VALVOLE Technical Dept. for further information.



ATTENTION: it's user's responsibility to maintain the safety features of the product and of their components in case of maintenance / repair on their own.

4. TESTING

4.1 Before carrying out of any test, to verify there are no problems in the movement of the ball, make at least one complete stroke of opening and closing.

4.2 Valve must be tested using the following procedure:

- a) Place the ball in a semi-open position
- b) Pressurise the valve body, by water, with a pressure 1,5 times the maximum operating pressure at room temperature (See table at para 0.2)
- c) Verify that there are no leaks from the body seals
- d) Release the pressure
- e) Close the valve
- f) Pressurise the first seat with water at a pressure 1,1 times the maximum operating pressure at room temperature (See table at para 0.2)
- g) Verify that there are no leaks from the end opposite to that pressurised
- h) Release the pressure
- i) Pressurise the second seat (if present) with water at a pressure 1,1 times the maximum operating pressure at room temperature (See table at para 0.2)
- j) Verify that there are no leaks from the end opposite to that pressurised
- k) Release the pressure and drain the valve completely of any water
- l) Repeat the tests described in points f) and i) using air at 6 bar and verifying that there are no leaks from the end opposite to that pressurised



WARNING: during the test, valve must be firmly blocked on the test rig to avoid any possible danger to personnel caused by the pressure.

ALFA VALVOLE declines all responsibility regarding damage to things or people following to tests carried out in accordance with the above procedure.

ATTENTION: while considering the above information sufficient for proper execution of the maintenance of the valve, ALFAVALVOLE not give any warranty on the outcome of the intervention, not extended warranty, unless the action is performed by ALFA VALVOLE personnel at its workshops.

5. HOW TO ORDER SPARE PARTS

5.1 User must specifies, when ordering spare parts:

Valve model
Nominal diameter
Pressure class
Identification number or name of the part to be substituted (ref. attached card)
Material of the spare part (or of the original part)
Original order number or serial number of the valve

6. WARNINGS AND USE LIMITATIONS

6.1 Here described valves are intended for use with clean or slightly abrasive fluids (without solid particles).

ATTENTION: their use with abrasive fluids can cause the rapid decay of the sealing characteristics of the valve during operation; Any presence of solids or the use with hardening fluids which harden can cause a quick reduction of the tightness and of the operability.

6.2 User must provide adequate methods to eliminate risks associated with the temperature of the external surface of the valve during operations.



ATTENTION: User must evaluate the valve body surface temperature when the outside ambient has potentially explosive conditions.

It is not possible to identify the body surface temperature in accordance to the Directive 94/9/EC "ATEX" because it is a function of handled fluid temperature (surface temperature of valve body tends to reach the temperature of intercepted fluid).

User must provide appropriate methods to reduce the surface temperature of the valve body when the temperature of the intercepted fluid exceeds T6 limit.

During services with fluids at room temperature and in the presence of repeated manoeuvres, at intervals not greater than 1 operation every 10 seconds, the valves do not exceed 60 ° C (T6 class temperature, according to EN 13463-1).

6.3 Valves must be used within maximum and minimum values of temperature and pressure above indicated or in nameplate. For further details about maximum allowable pressure/temperature combinations please contact ALFA VALVOLE technical department.

ATTENTION: User must provide suitable means against the exceeding of the operating limits.

6.4 Before carrying out of any intervention on ball valve, verify that there is no pressure in the body cavity by carrying out a complete opening and closing cycle.



6.5 **ATTENTION :** before removing any service connection such as drain plugs, vents, sealant injectors or stem, make sure of the absence of pressure inside the body cavity of the valve.



The removal, even if accidental, of drain plugs, vents or sealant injectors may cause a dangerous sudden discharge of pressure to the atmosphere -and the expulsion of the organ itself.

Before carrying out this operation however, we recommend the use of personal safety equipment.

6.6 Before doing any intervention, ensure that no dangerous residue is contained in the valve body. The valves must be completely drained and cleaned in the cavity around the ball before any intervention.



WARNING: any entrapped residue will be expelled from the ends of the valve.

6.7 **ATTENTION:** when installing the valve, User must ensure the same equipotential electrical level between valve and piping system in order to prevent electric shock.



6.8 **ATTENTION:** when used in a potentially explosive area, for the purposes of Directive 94/9/EC "ATEX", User must provide appropriate means to avoid impacts of metal parts against the valve body during assembly, service time and maintenance.



6.9 Quick closure of the valve against high speed flows can cause overstressing of the seats due to "water hammer", which can determine reduction of valve tightness.

ATTENTION: User must provide suitable means against the effects of "water hammers".

6.10 The maximum number of operating hours can be influenced by the real operating conditions.

ATTENTION: User must evaluate the minimum time between inspections, basing on actual operating conditions, in particular in relation to the degree of corrosion/year used in the piping design with reference to the corrosion overthickness (see para.0.3 of this manual).

Time between inspections should not be longer than 2 years or 5.000 full open and close strokes.

6.11 **ATTENTION :** the user must carry out periodic inspections in order to eliminate any accumulation of powder greater than 5 mm in correspondence with the sliding surfaces of the stem/valve body and actuator pinion /actuator body.



6.12 ATTENTION: the functioning of valves complete with actuators is not guaranteed in the event of an earthquake due to possible misalignment of connection between valve stem and actuator pinion.
 Valve and actuator assembly is calculated for a maximum earthquake magnitude incrementing 40% the dead weight of actuator and valve cover.

6.13 ATTENTION: assembling of actuators for valve operation different to that supplied is not allowed without previous approval from the manufacturer.

6.14 Actuators, any type, are not suitable to resist against external fire conditions.

ATTENTION: actuators fire-safe properties can be obtained by use of fire-protection boxes enabling, to avoid system (valve+actuators) malfunctions.

6.15 ATTENTION: cabling of actuators and electrical accessories should be realized after valve mounting to piping system and according to the specifications showed in the relevant use and maintenance manuals.



6.16 ATTENTION: the user must establish an appropriate control program to verify the integrity of the lubricating grease in the manual gears, if installed.

6.17 ATTENTION: split body type valves are suitable for resisting to reduced axial forces from piping system.
 If necessary, require maximum values of allowed axial loads from ALFA VALVOLE technical department.

6.18 ATTENTION: valves can be used as end-type valves only by specific customer request and for working pressures not exceeding 77% of the stated maximum working pressure at room temperature.

7. TROUBLE SHOOTING

MALFUNCTION	POSSIBLE CAUSE	ACTION
Leakage through the valve	Ball surface damage	Replace the ball
	Seat damage	Replace the seats or try with injection of sealant grease (trunnion mounted construction only)
	Not complete closure	Check Open/Close limits and settings
Ball movement not regular (actuated valves)	Dirt between ball and seats	Flush the inside, operating the valve 5 times
	Dirt between ball and body cavities	Flush the inside, operating the valve 5 times
	Not sufficient air supply flow	Confirm working conditions are as per request
	Not sufficient air discharge	Include quick exhaust valve
Valve torque too high	Seat damage	Replace the seats
	Dirt between ball and seats	Flush the inside operating the valve 5 times
	Dirt between ball and body cavities	Flush the inside operating the valve 5 times
	Excessive Pressure or Temperature	Confirm working conditions are as per request
Stem leakage	Stem nuts loose	Tighten stem nuts
	Damaged stem seal surfaces	Replace stem
	Damaged stem seals	Replace stem seal or try with injection of sealant grease (trunnion mounted construction only)
Body seal leakage	Gasket damage	Replace gaskets
	Excessive Pressure or Temperature	Confirm working conditions are as per request
	Excessive load from piping system	Verify piping system architecture
Excessive valve noise	Error in valve sizing	Confirm valve sizing
	Not complete opening	Check Open/Close limits and settings
Fail in valve movement after electrical input (actuated valves)	Solenoid valve fail	Confirm power supply Replace the solenoid
Fail in limit switch signal	Incorrect settings	Check Open/Close settings
	Limit switch is broken	Replace limit switch
	Incorrect power supply	Confirm working conditions are as per request

MAINTENANCE CARD

ALFA 10N/NF/HP - 103

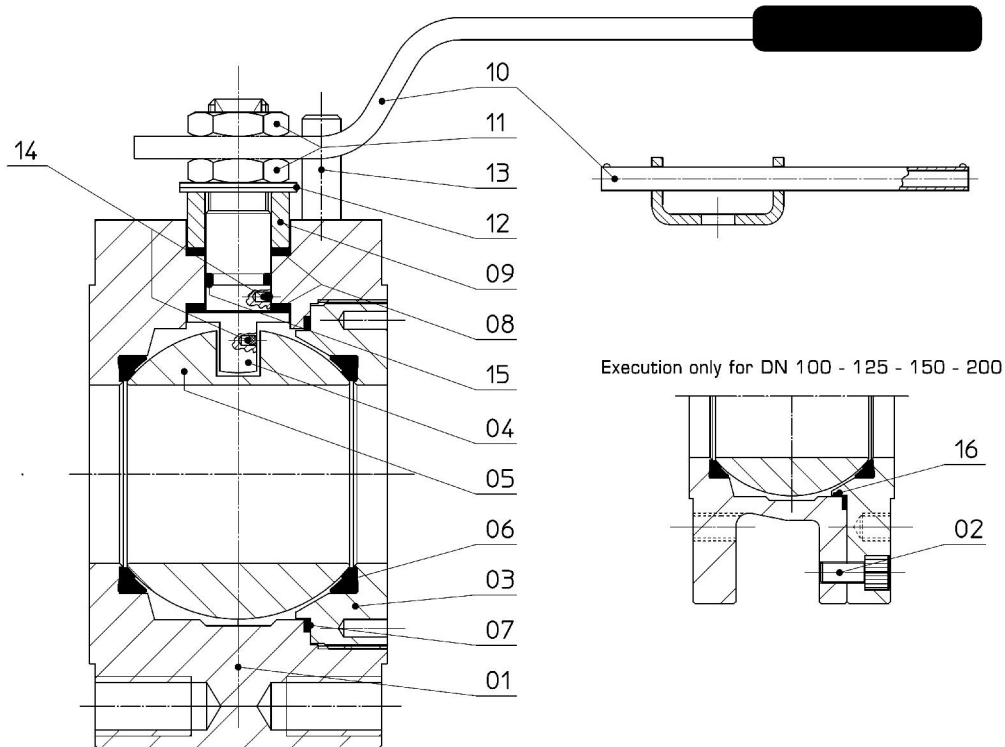

PREMISE regarding ball valves type ALFA 10, 10N, 10NF, 10HP, 11, 103

ALFA WAFER COMPACT BODY BALL VALVES type 10 / 10N / 10NF / 10HP / 11N / 11NF / 103 / 103HP / 104 derive from a common design, therefore the maintenance card is shared between the nine models

REPLACEMENT INSTRUCTIONS FOR WORN OUT PARTS

VALVE DISASSEMBLY

1. Remove the valve from the pipe system
2. Clean the residual piping product from valve, especially if toxic or harmful.
3. Block the valve in a parallel-jaw vice
4. Countersign the position of the RING NUT (item n°03) marking a reference line with a marking tool or with a pen.
5. 5a) Unscrew and remove the RING NUT (item n°03) from the BODY (item n°01) with a proper tool (a pin spanner).
5b) For valves with Bolted Closure, (DN 100-125-150-200) unscrew the HEXAGON SOCKET HEAD SCREWS (item n°02) fixing the CLOSURE to the BODY with a proper spanner, and then remove the CLOSURE.
6. Raise and remove the BODY GASKET (item n°07) with an extractor tool.
7. For valves with double sealing, raise and remove also the BODY O-RING (item n°16) from its groove.
8. Set the valve in "Closed Position", by shifting the LEVER (item n°10) and remove the BALL (item n°05). In this position the Tang of the Stem and the Slot of the Ball shall be in line with the extraction movement. Inspect the Ball's spherical surface and in case of furrows or damages, replace the Ball.
9. Raise and remove the two SEATS (item n°06), one from the Body and one from the Closure, with an extractor tool. Clean the Seats carefully and in case of furrows or damages replace them.
10. Unscrew and remove the STEM NUTS (item n°11) from the Stem. Remove in succession the BELLEVILLE SPRINGS (item n° 12), the PRESSING BUSH, and the first STEM WASHER (items n°09 and n°08). Remove the STEM (item n°04) with the second STEM WASHER (item n°08). Remove the STEM O-RING (item n°15) from its slot.

Inspect the worn out conditions of all items and replace the damaged ones.

The standard spare parts kit (parts that is recommended to replace during every valve disassembly) is composed by:

- BODY GASKET (item n°07) – 1 pc.
- BODY O-RING (item n°16) – 1 pc.
- SEATS (item n°06) – 2 pcs.
- BELLEVILLE SPRINGS (item n° 12) – 2 pc.
- STEM WASHER (item n°08) – 2 pcs.
- PRESSING BUSH (item n°09) – 1 pc.
- STEM O-RING (item n°15) – 1 pc.

1. Take the BODY VALVE (item n°01) and assemble on its housing one of the two SEATS (item n°06); from the inside insert the STEM (item n°04), on which the first STEM WASHER (item n°08) has been already assembled in its slot plus the O-RING (item n°15), until it emerges from stuffing box; then insert the second STEM WASHER (item n°08), the PRESSING BUSH (item n°09), the BELLEVILLE SPRINGS (item n°12), and last the LOCK NUT (item n°11). Tighten without pressing the assembly.
2. Insert the BALL (item n°05) so as its Slot fits the Tang on the Stem, then move the Ball in "Closed Position"; if allowed from the boundary conditions (media, materials, ...) apply a few drops of lubricating mineral oil in order to minimize friction and help the ball to settle with the seats.
3. Assemble the second SEAT (item n°06) in the CLOSURE (item n°03) Housing, insert the BODY GASKET (item n°07) in its own groove, the BODY O-RING (item n°08) if present.
4. 4a) VALVES WITH RING NUT: Screw the RING NUT (item n°03) onto the BODY with a Pin Spanner, torque values according table A.
 4b) VALVES WITH BOLTED CLOSURE: Bring together the CLOSURE with the BODY matching Body Holes with the Closure Holes, insert the HEXAGON SOCKET HEAD SCREWS (item n°02) and tighten lightly only using your hands.
5. Assemble the complete unit, press firmly the valve flange onto a vice and prepare to tighten the SCREWS using a proper spanner; proceed gradually and crosswise: arrive to final lock only when all SCREWS (eight, twelve or sixteen, depending from the valve diameter or rating) are tightened so as to have the Closure well adherent to Central Body. At this point screw firmly the LOCK NUT (item n°11) on the STEM. Tighten the gland nut with a torque value according table B.
6. Screw the STOP PIN (item n°13) on top of the stuffing box plane, fit the LEVER in position in order that, with the Ball in "open position", the LEVER (item n°10), is aligned with the flow direction: Please note that the Lever rotation from the "open position" to the "closed position" shall be Clockwise. For the Stop Pin assembly, choose between the two holes that allow this type of rotation the one closer to the Closure.
7. Assemble the LEVER (item n°10) on the Stem, and tighten it using the LOCK NUT (item n°11).
8. Check the Ball Rotation Resistance. The force applied on the hand lever needs to be homogenous during all the rotation.

TABLE A - RING NUT TIGHTENING TORQUES

DN	RING NUT THREAD	TORQUE (Nm)
15	M42 x 1,5	160
20	M50 x 1,5	150
25	M60 x 1,5	200
32	M70 x 1,5	255
40	M78 x 1,5	380
50	M94 x 1,5	550
65	M107 x 1,5	700
80	M131 x 2	900
100	M151 x 1,75	1050 (*)

Given torque values needs to be settled or on a torque spanner or on a pneumatic screwdriver.

The given values are subjected to a variance of approx. 10%.

(*) Only 10N type. 10NF is with bolted closure

TABLE B - STEM NUT TIGHTENING TORQUES

DN	STEM NUT THREAD	TORQUE (Nm)
15-20	M10 x 1,25	12
25-32	M12 x 1,25	20
40-50	M16 x 1,5	45
65-80	M22 x 1,5	90
100-125	M30 x 2	180
150	M45 x 3	370
200	M52 x 3	600

Given torque values needs to be settled or on a torque spanner or on a pneumatic screwdriver.

Given torque values are for standard floating ball valves with P.T.F.E. or TFM seats. For other configurations contact Technical Dept.